

OPERATING AND COMMISSIONING MANUAL



In compliance with the current norms, the machine should be installed only by a technical person qualified for this type of work. During installation, ensure that:

- The machine is moved as given in chapter II.1.
- The required personal protection devices are worn so as to avoid injuries caused by electrical and mechanical hazards (injuries by touching panels, sharp edges, etc.)
- Electrical connections are made after the power supply has been shut off, in compliance with the recommendations given in chapter III.
- Grounding is carried out in compliance with current standards.
- The machine is powered on when installation has finished (ducting installed and inspection doors closed).

I / RECEIVING THE EQUIPMENT

Diablo are delivered on stringers or palettes then wrapped in plastic film..

I.1 / Receipt of the goods

When the equipment is received, the state of the packaging and the equipment must be checked. In the event of damage, make an accurate note of any problems on the carrier's delivery note.

I.2 / Unpacking

When the equipment is unpacked, check the following:

- The total number of packages are present.
- All accessories are present (dampers, roof, electric switchgear, etc.). After unpacking the equipment, the waste must be disposed of in compliance with the current standards. No packaging should be discarded into the environment

I.3 / Storing

The equipment must be stored in shade, in a dry place, at a temperature between -20°C and 40°C.

II / INSTALLATION

II.1 / Handling

The units must only be moved in their installation position.

If the device is handled using a fork-lift truck, ensure this supports the load-bearing structure and does not touch the panels enclosing the unit.

If the device is moved using a crane, use four cables of identical lengths. These must be at least as long as the greatest distance between two fastening points.

If $L + W + H > 5m$ \Rightarrow then the case must be lifted using a lifting beam.

II.2 / Space required

Generally speaking, it is desirable to provide access space of at least the width of the unit on the access side for maintenance.

II.3 / Installation

The unit must be laid on a sufficiently rigid and flat surface (use vibration mounts if necessary). For the DIABLO connection, select duct sections based on dimensions of the flexible bands that should be properly stretched. Install the unit such that bad weather or ambient temperature cannot damage the internal items of the unit during installation as well as when used later (possibly provide a protective cap).

Outdoor installation DIABLO/DIABLO TWIN :

To raise the Diablo (out of the water) you can use optionnal set of feet (PCB). From size 630 DIABLO TWIN is supplied with frame as standard equipment. An outdoor kit is also required (see chapter V /Accessories).

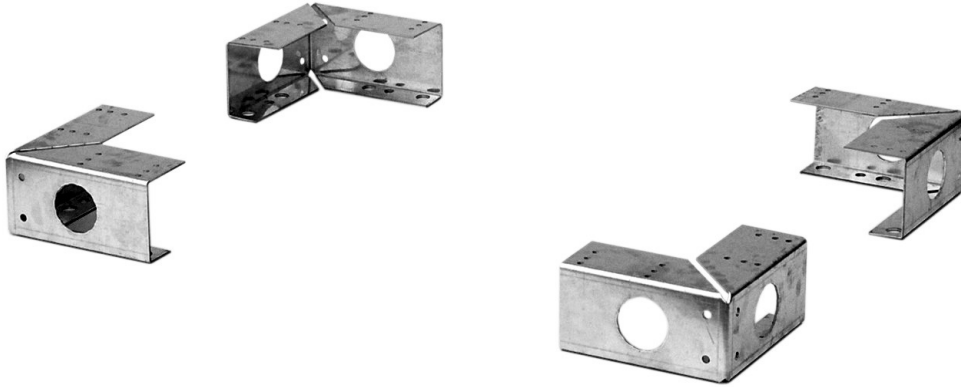

BEFORE SWITCHING ON THE DIABLO PAY ATTENTION THAT ALL THE SCREWS ARE WELL TIGHTENED, IN PARTICULAR THE ROTATING COMPONENTS.

III / ELECTRIC WIRING OF THE 3-PHASE MOTOR

Electric connection will be done on the padlockable switch or on the optionnal control box mounted on the DIABLO® DIABLO TWIN®. In this case refer to the manual with control box.

III.1 / 1 speed motor

1 Speed - 2 tensions (Star - Delta connexions) (230V/400V) (4-6-8 poles)

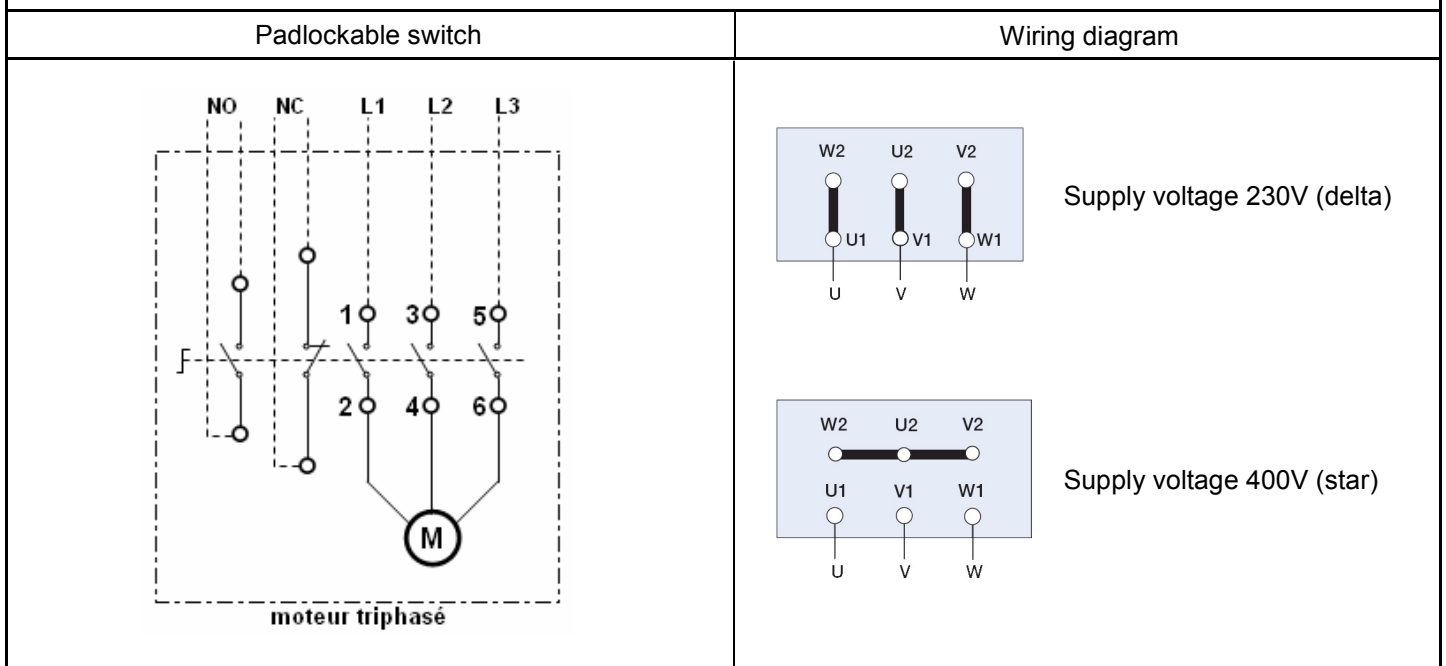

III.2 / 2 speeds motor (Dahlander)

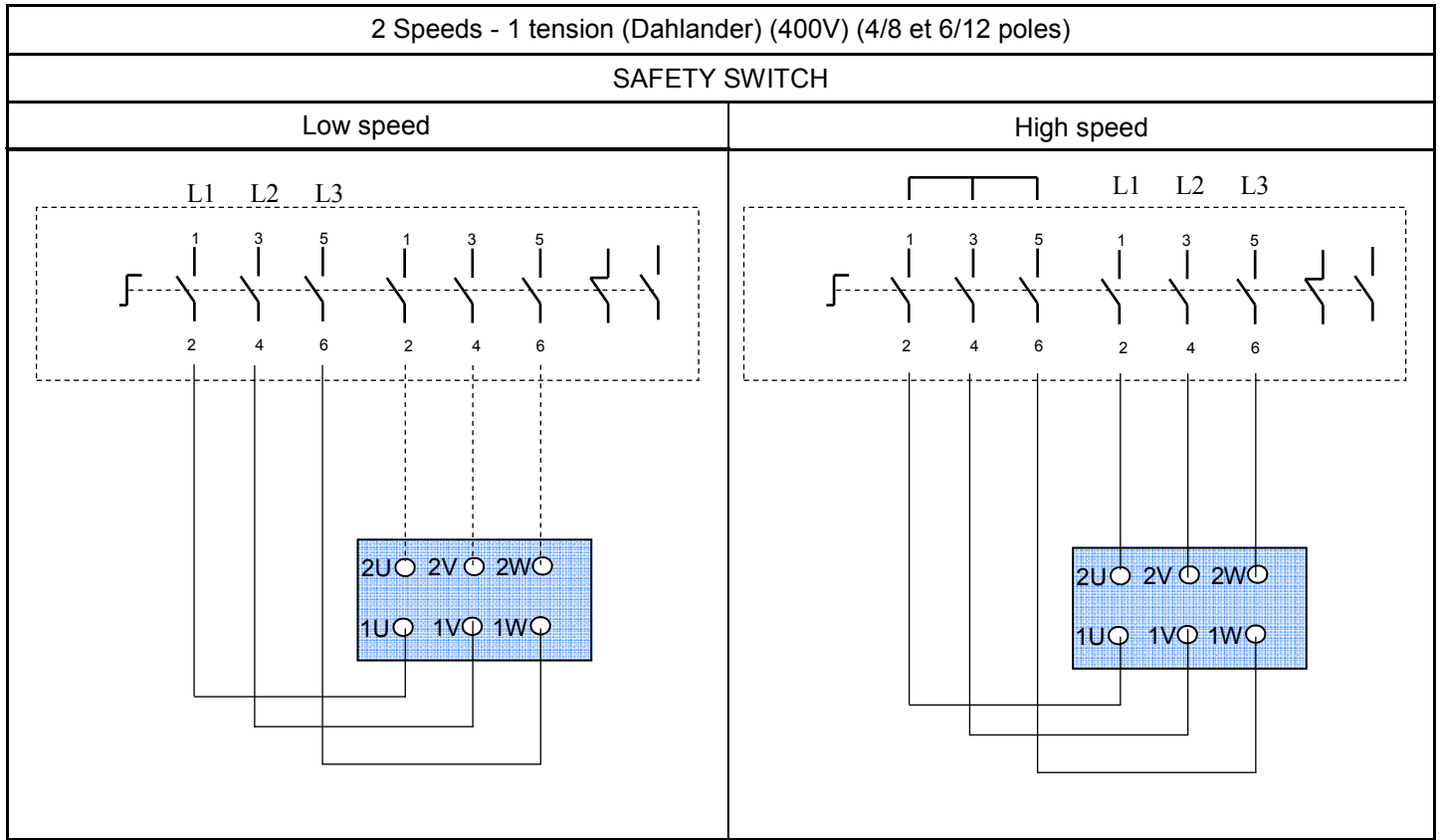

III.3 / 2 Speeds motor (Separated coils)

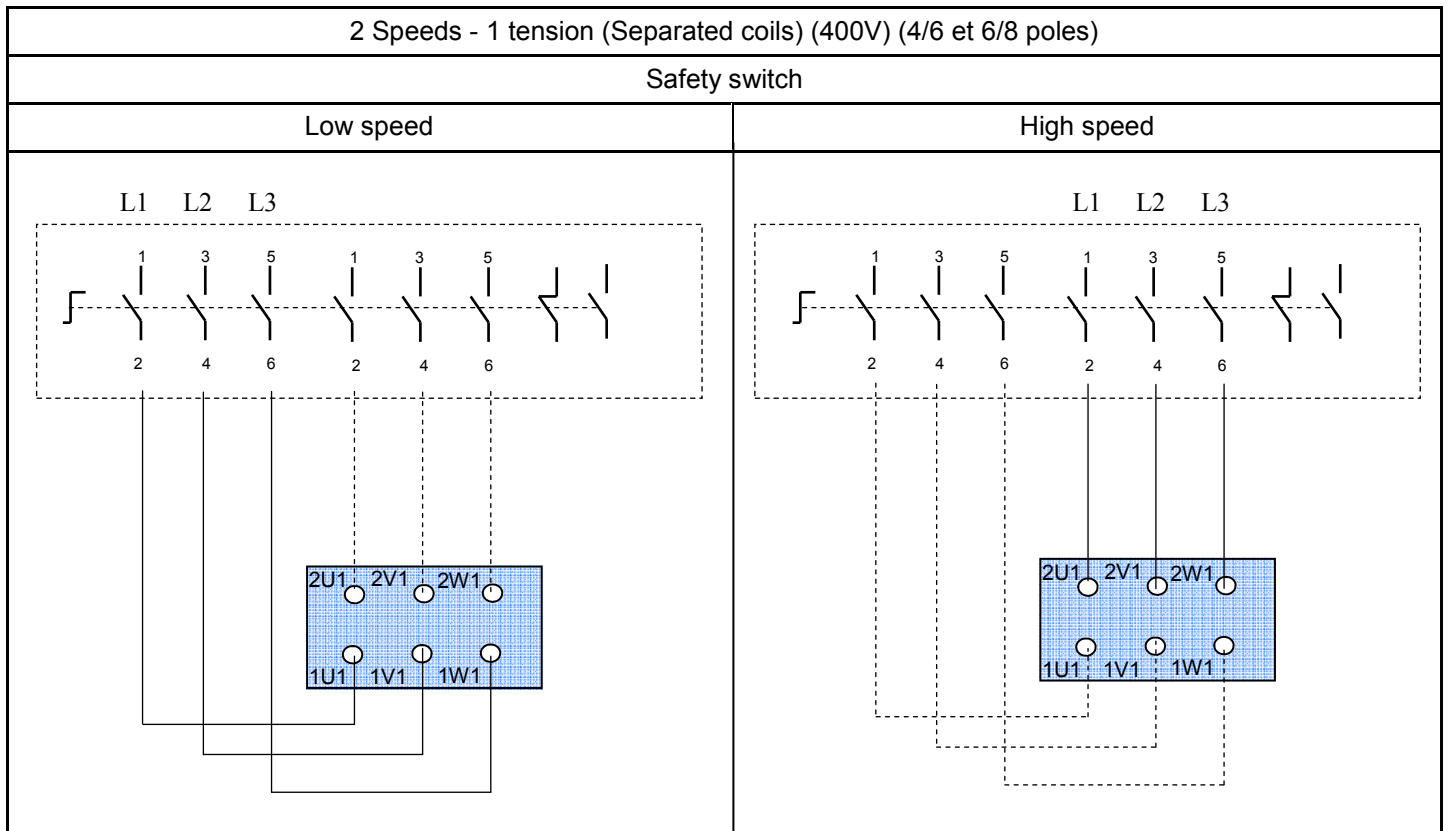

IV / COMPONENTS

IV.1 / Motor

- The electrical conduits of the smoke exhaust fan do not need protection against overloads but only magnetic , in accordance with norm ref NFC15-100 , they must be dimensionned with highest overloads that motor can stand. Power supply must be provided by heat-resistant cables **CR1**.

Inside the rooms cables must be resistant enough to ensure good functioning of the DIABLO during smoke exhaust.

- Check the tension of the grid which must be the same as written on the moteur plate

- If the diablo is used in confort , connect PTO if they are on the motor.

- When starting the unit , check the absorbed intensity of the motor which must be the same as written on the mo- tor plate. In case of overcurrent stop the unit and contacte your retailer.

IV.2 / Fan

When wiring is finished, **check the direction of rotation of the fan** (reverse 2 of the phases on the motor to invert the direction of rotation).

NOTA : a fan that does not rotate in the right sens do not have an apposite airflow but an airflow lower than forecasted An extended use on of the fan rotating in the wrong direction may produce vibrations and dammage motor bearings.

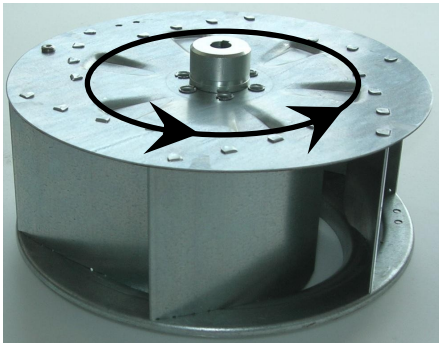

ATTENTION : For 2 speeds motor check that motor turns in the same direction in high and low speed.

V / ACCESSORIES

IV.2 / DIABLO Outdoor Kit (KED)

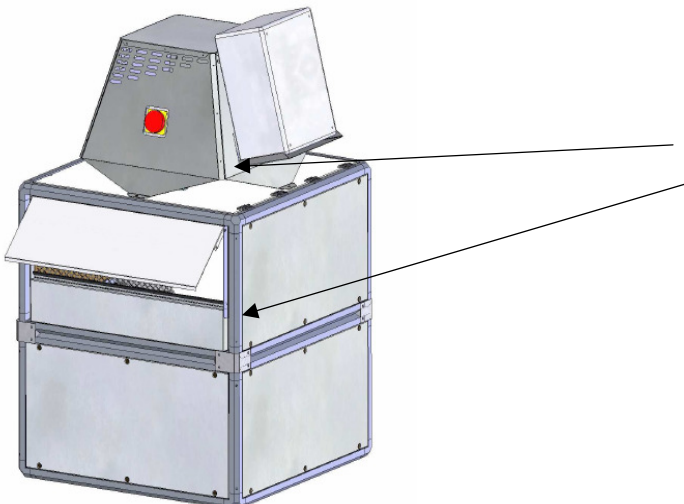

The DIABLO outdoor kit supplied as standard equipment includes:

- Roof
- Motor cover (mounted)
- Rain visor with grill on discharge

IV.3 / DIABLO TWIN (KED TWIN) outdoor kit

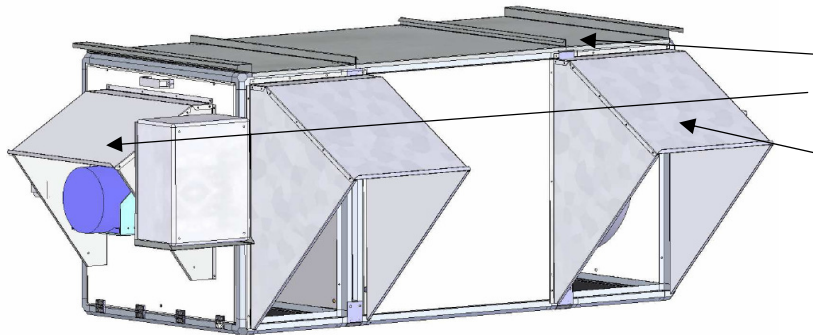

DIABLO TWIN Outdoor kit mounted in standard includes:

- A roof in 3 pieces (mounted)
- Two motor covers (monted)
- Two rain visors with grill on discharge (to be mounted on site)

Rain visor must be mounted with provided screws as seen on the drawing:

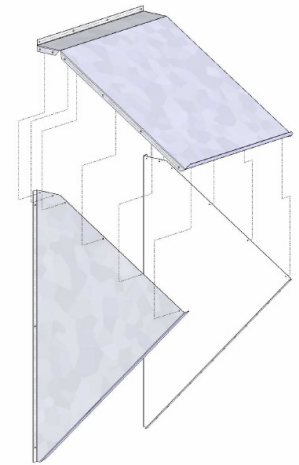

V.3 / Optionnal electric accessories

For optionnal electric accessories (Dahlander, separated coils, control box) refer to their manuals.

V.3.a / Control box

Control box (**CDF**) can be mounted directly on DIABLO® DIABLO TWIN®

The 2 motors of DIABLO TWIN® can be controlled with one control box. In this case check that it can hold with the intensity of the 2 motors.

V.3.b / Speed variation with frequency convertor

The speed of the motors can be modified with frequency convertor only on variable comfort.

The speed variation is not possible in smoke exhaust running.

Convertors are mounted under motor covers for outdoor installation or on the motor support in standard. This configuration has F400-120 certification.

When only using in variable comfort (electric connection without logic 400-120 control box), speed variation can be done with VFT or VFM frequency convertor.

When using in variable comfort and smoke exhaust (electric connection with a logic 400-120 control box), speed variation can only be done with VFT or VFM frequency convertor.

Speed variation is only possible with 1 speed motors (4,6 or 8 poles), of a power higher or equal to 0,37kW.

The 2 motors of DIABLO TWIN® can be controlled with one frequency convertor .
In this case you need to oversize frequency convertor of 1 size. Ex : 2 x 0,37kW = 1,1 Kw.

